

Stephen Hughes works for the **Royal Commission on Ancient and Historical Monuments in Wales** as an Investigator of Industrial Monuments. For nine years he has been doing preparatory study for a series of large volumes on the archaeology of canals and early railways in Wales and concentrated initially on the Montgomeryshire Canal. In many IA circles he is now affectionately known as 'Mr Montgomeryshire'.

One thing led to another and after writing a twenty-page article for *Montgomeryshire Collections* in 1981, a gazetteer and extra illustrations were added and a thirty-two page booklet was published under the same title as the county magazine piece; *The Industrial Archaeology of the Montgomeryshire Canal*. The entire print order (600) was taken up in eight months and it is currently being reprinted, pending a new edition, which should appear in 1984/5.

Now if it should be thought that Stephen Hughes's Montgomeryshire enthusiasm is a thing apart from his general duties with RCAM (Wales) I hasten to say that far from this being the case, there are a host of 'colleagues' involved; Brian Malaws, Iain Wright, Jane Durrant and Tony Parkinson, and on the showing so far, the Welsh Commission is heading the field in practical industrial archaeology.

RCAM (Wales) must be recognised in IA high places, for when the CBA Industrial Archaeology Committee held their *Crisis in Recording Industrial Monuments* meeting in November 1981 (reported in Bulletin 9/3) it was suggested that the various Royal Commissions might use their undoubted surveying and recording expertise to train IA students. Stephen was then able to point out that the Welsh Commission were already doing just that.

In fact they had arranged to administer the 'surveying and recording' component of the Institute of Industrial Archaeology IA Diploma Course for 1982-83, **naturally** along the Montgomeryshire Canal.

And it came as no surprise that an MSC scheme was proposed and eventually approved to employ four RCAM (Wales) trained people to (in official language) **survey and research industrial archaeological monuments on the Montgomeryshire Canal**. This is now going ahead and will provide additional material for the revised edition of 'the book'.

A splendid story of enthusiasm and down-to-earth hard work by everyone concerned, not least the Royal Commission itself which it

getting a steady stream of new surveys and additional information deposited with the National Monuments Record for Wales, an archive which is meticulously indexed, kept at the Commission's Aberystwyth office: Edleston House, Queen's Road, Aberystwyth, Dyfed SY23 2HP, telephone 0970 (STD) 4381/2, and can readily be consulted by the general public.

Details of the Montgomeryshire project. Where, you may ask, is the Montgomeryshire Canal? The book contains a towpath-type-map of the entire length and this introductory paragraph:

The 'Montgomery Canal' is today defined as the line of waterway stretching from the Llangollen Canal at Welsh Frankton in a south-westerly direction through Llanymynech

and Welshpool to Newtown. In fact, this 34 mile length consists of four completely different canals which have been linked in name only under modern ownership. The objective of all four canals was to carry and distribute lime for agricultural purposes from the lucrative quarries at Llanymynech Hill, the carriage of this lime substantially outstripping any through-traffic likely to emerge. Two canals stretched out on either side of Llanymynech quarries from a common terminal nearby.

It also contains 29 pages of text, 24 photographs, 5 drawings (including the magnificent cut-away by Geoff Ward reproduced on this page and 5 other maps. If you can get one (try writing to Stephen Hughes) they are £1.95 including postage. However potential buyers could have to wait for the reprint.

Powis Estate Sawmill, Welshpool (powered by canal-water)

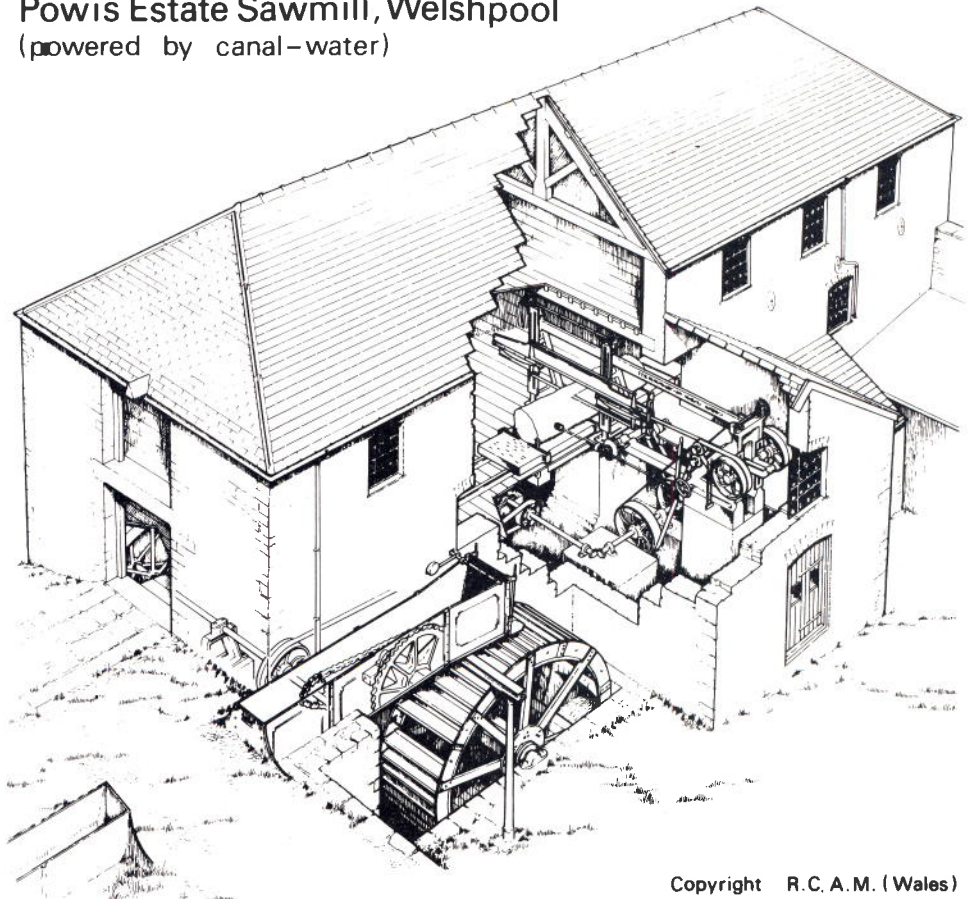

COTTAGE AT BELAN LOCKS, WELSHPOOL, POWYS

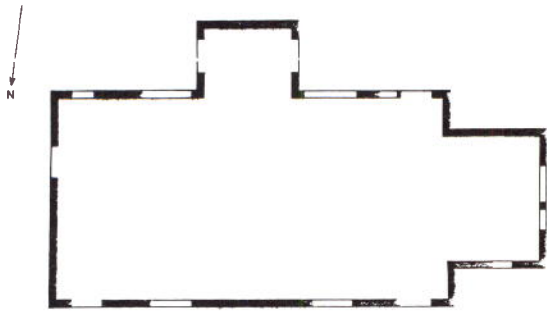

Ground Plan



West and East Elevations

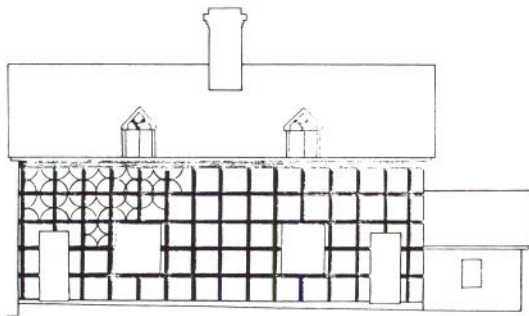

North Elevation

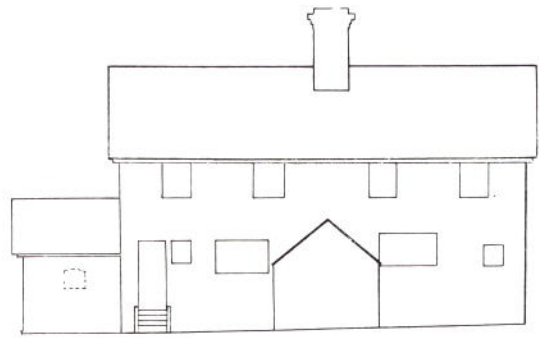

South Elevation



Surveyed by BM, F.O., M.J.S., J.C.T.
Drawn by KO, J.C.T.

The survey for the Institute of Industrial Archaeology's 1982/3 Diploma Course has produced an excellent series of additions to the RCAM (Wales) archive including this Cottage at Belan Locks, Welshpool.

It has also resulted in a set of notes on surveying industrial buildings prepared by Brian Malaws and Tony Parkinson, and which are reproduced below.

Very Basic Notes on Industrial Buildings

1 Preliminary

It doesn't matter what units you measure in as long as they are stated on the survey drawings, so that if necessary someone else can plot from your notes. Show feet and inches as (for example) 6/2 (= 6 ft. 2 in.) or 14/- (= 14 feet 0 inches) &c. A dimension in the apparently simple metric system can be expressed in several ways; for example, to express 13.200 metres and 0.765 metres you can write 13.2, 0.765 metres; 1320, 76½ or 76.5 centimetres; or use the British Standard system of 13 200, 765 millimetres. Whichever system you use, be consistent.

2 Survey Team:

Two people are better than one, three is best. The 'leader' books the measurements and directs operations; the second reads the tape or rod and the third (if available) holds the zero end of the tape for the leader. Each team requires a tape (20 m/50 ft. or longer), a 2m/6 ft. folding rod or steel pocket-tape, several sheets of A4 size (A3 is better) paper clipped to a rigid board, an HB pencil, a red pencil and a rubber.

3 Measuring Plans:

In each room:-

a) Sketch the room at a large scale using conventional representations of doors, windows &c. Draw everything to be measured. Don't try to make your sketch a scale drawing, exaggerate small details to enable all the dimensions to be fitted in clearly. If a sketch becomes cluttered draw 'details' at a large scale and note 'see detail' on the main sketch.

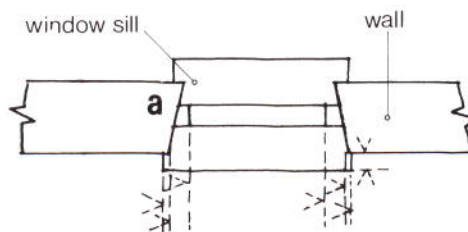

Not this...

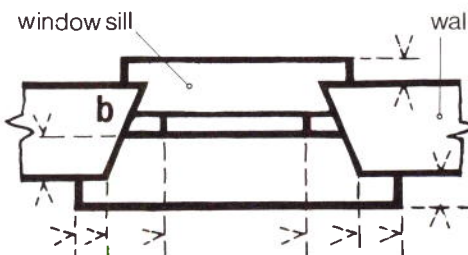

dimension lines and arrow heads in different colours

But this...

It is helpful to use a different colour for dimension lines and arrows so as not to confuse the drawing, but write all dimensions in ordinary pencil.

b) Measure each wall systematically and book each measurement. Start with tape zero on the left hand edge of a wall and measure to the right. Apart from enabling you to read the tape the right way up, it is easier to plot as scale rules are usually graduated from left to right. If you are measuring single-handed it may be quicker to fix a nail or pin in two opposite corners and measure outwards from each pin to record the four walls, and then between them to get the diagonal.

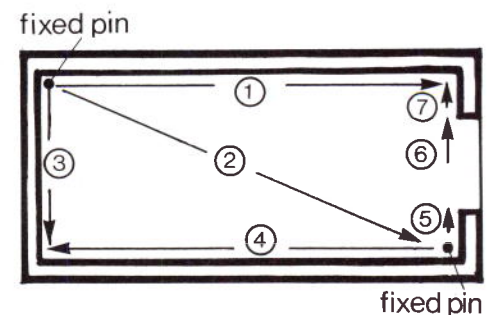

Always take running measurements where possible as this minimises movement, is more accurate, and is easier to plot.

c) Measure and book the diagonals; although one will suffice, taking both serves as a check. Note the exact points measured.

d) Measure and book extra details, eg fireplace or alcove depths, wall-to-glass distances at windows and wall thicknesses.

e) Remember that you are trying to create a grid of interlocking triangles with wall junctions at their apexes. When plotting, you are merely re-creating this grid of triangles at a smaller scale and joining their apexes to form the plan of the room or building.

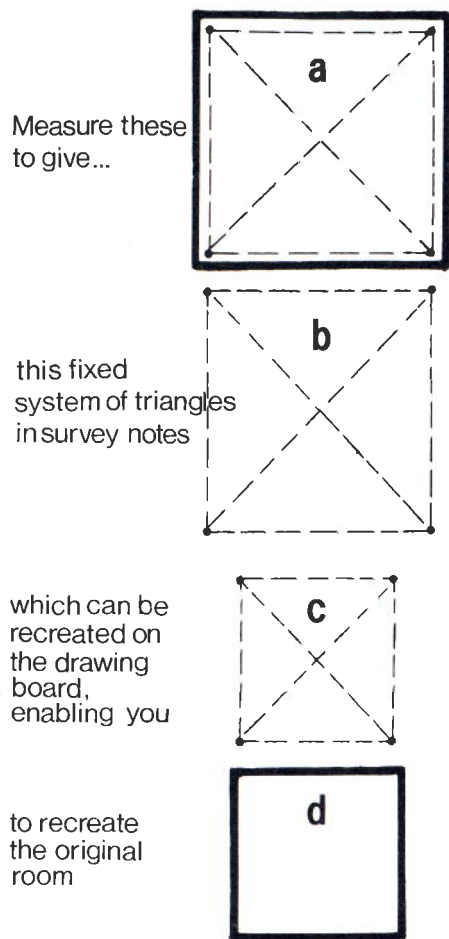

No more than one sketch per floor of a building is preferable; this avoids missing out wall-thicknesses where sketches meet and makes it possible to note measurements from one room to another. If a second sketch is needed, mark the junction points clearly.

These rules (except c) also apply to exterior plans.

4 Measuring Elevations and Cross Sections:

- Sketch, as 2a) above.
- Measure details horizontally if they will not appear on plan.
- Record details vertically by taking a datum line (eg a level line of window sills) or creating one (eg chalk or string line set up with a spirit- or dumpy-level) and measuring up and down to it. If you use several datum lines, as on a multi-storey building, ensure that the heights between them are booked. The horizontal datum lines are thus easily re-created on paper, enabling features to be drawn in vertical relation to each other.
- Cross-sections:- Check floor thicknesses at stairs. Obtain structural details of the roof by setting a datum line across the building; measure vertically from it to key points on the roof trusses and record the distances along the datum.

e) Supplement elevations drawings with photographs.

5 Plotting:

- Bear in mind the purpose of your drawing and use an appropriate, recognised metric (or imperial) scale. Plot a scalebar on your drawing so that if it is reduced or enlarged it is still usable; simply stating 1:100 or 1:96 or whatever on a drawing is not enough.
- Plot with a soft but sharp pencil on a stable material: Permatrace or similar is best, good drawing card (not multi-layer like mounting- or watercolour-board) or cartridge paper is OK, tracing paper is almost useless.
- Don't try to make a finished drawing straight away. You are producing a **plot**; a high quality drawing for publication or exhibition must be traced on another sheet using the plot as a basis.
- Build up each room using diagonals and wall lengths to form adjacent triangles; fit exterior dimensions to interior at door and window openings.
- Put in North point; this may be worked out either using a compass on site, or from a large-scale Ordnance Survey map (6" to the mile or larger).

And appropriately the following was released from the British Waterways Board office in June of this year.

Montgomery Canal – Full Restoration is Justified say Consultants.

At a meeting in Shrewsbury in June 1983, the findings of Consultants who were appointed to study the economic, social and environmental benefits of restoration of the Montgomery Canal were presented to an invited assembly of sponsors and organisations interested in the waterway. The findings concluded that the greatest economic benefit would be achieved by the completion of the project for restoration to cruising standard in the shortest possible time of the whole 33 mile length of waterway between Newtown Pump House, Powys, and its connection with the national canal network at Frankton Junction, Shropshire, together with the short Guilsfield Arm.

The cost of full restoration is estimated at £9.4 million, and the additional annual maintenance costs at £84,000. The return to the local community from increased tourist expenditure would be over one million pounds a year, and the equivalent of 186 full-time jobs could be created in the towns and villages along the waterway. A much improved recreational and leisure facility would be available for the enjoyment of all.

Welcoming the report, the Chairman of British Waterways Board, Sir Frank Price DL, who chaired the meeting, said that, with the support of local authorities and voluntary organisations, the Board had achieved considerable success in restoring derelict waterways for recreation. In February of this year, some 80 miles of restored waterways had been added to the 'Cruising' network. Full restoration of the Montgomery Canal would be a significant addition to the leisure waterways and be of lasting benefit to the local community.

The study, which was presented by consultants W S Atkins and Partners was commissioned by a consortium led by the Welsh Development Agency. The other partners are British Waterways Board, Shropshire County Council and Inland Waterways Association.

Opening of First Major Inland Transport Waterway since 1905.

Sir Frank Price, Chairman of British Waterways Board, recently unveiled a commemorative plaque at Eastwood Lock, Rotherham to open the improved section of the Sheffield and South Yorkshire Navigation and which allows suitably designed craft of up to 700 tonne pay-loads to navigate inland between Rotherham and the Humber Ports.

The Mayor of Rotherham, Councillor J Allott, then renamed the lock 'Frank Price Lock' in recognition of his major contribution in leading the campaign in close co-operation with South Yorkshire County Council and Rotherham and Doncaster Metropolitan Borough Councils, to bring a modern, economic transport waterway to the industrial heartland of South Yorkshire.

The Scheme, which cost £16 million has been funded by central government and grants from the Regional Development Fund of the EEC and South Yorkshire County Council. In all ten locks have been rebuilt or enlarged within the provision of the Scheme since construction work started in April 1979. Other major works included the modification or rebuilding of eight road and rail bridges and seven major channel widening, re-alignment and river diversion schemes necessary to allow large barges to navigate the waterway.

Information Required. Derbyshire Museum Service has received a request for information on the firm of D Ath & Elwood.

It is believed that this firm made the steam winding engines for Nailstone & Bradley Collieries (Nr Stockport). Research in the Museum's files and those of The Derbyshire Record Office have not produced any information whatsoever. Anyone able to help is invited to get in touch with Maggie Heath at The Derbyshire County Museums Service, Matlock, Derbyshire DE4 3AG, telephone 0629-3411, extension 7399.

Industrial archaeology has a world-wide following and as more AIA members are looking for IA sites during their annual holidays it seems sensible to publish details of industrial archaeological interest abroad whenever available. The following feature on the tanning industry in France was sent to us by Roy Thompson a well-known authority on leather, its history and processing.

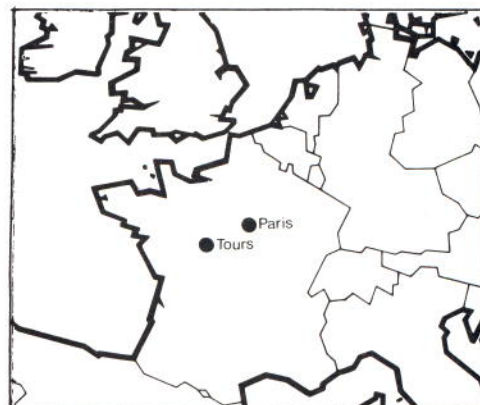

Chateau Renault – City of Leather. Chateau Renault is a town of about 6,000 inhabitants lying just north of the Loire Valley between Tours and Amboise. Today there are only two working tanneries left, but the view across town from the twelfth century castle tower shows exactly why the townspeople of a hundred years ago were justifiably proud in using the title 'City of Leather'. Along the banks of the two rivers that meet in the town are remains of many tanneries, identifying themselves as such by their louvred drying lofts. Between the buildings can still be seen the outlines of innumerable circular pits, reminiscent of the eighteenth century engravings of Diderot and Lalande.

The first evidence of leather manufacture at Chateau Renault comes from a document of 1323 which mentions a tanbark mill owned by a nearby monastery. It was not until the sixteenth century, however, that the town started to become a centre for the leather industry.

In the late 1530s when Diane de Poitiers became the mistress of King Henry II of France, he built her a magnificent chateau at Vendome. According to local tradition, all was to the satisfaction of Diane de Poitiers, except for the smell from the nearby tannery. The offending tanner, Bernard Peltereau, was forced to close down but, in compensation, he was granted Royal Letters Patent in 1543 authorising him to establish a tannery in Chateau Renault about 30 kilometers away.

Under such royal patronage, Bernard Peltereau prospered and, in 1597, another member of the family set up a second tanyard in the town. Over the next century, while the Loire Valley remained the centre of aristocratic activity, the demand for leather increased. By the end of the seventeenth century Chateau Renault had six tanneries employing altogether twenty-eight workmen.

Unfortunately this prosperity did not last. The Court returned to Paris and, in attempts to bolster royal finances, increasingly severe taxes were imposed on basic commodities such as leather. By 1781 the various duties on leather amounted to almost 60% of the sale price. As a

result, the tanning industry of Chateau Renault collapsed and, in 1788, there was only one tanyard left. With the coming of the French Revolution, the fortunes of the tanneries revived. The sales taxes were repealed and there was an immediate requirement for large quantities of leather for the Armies of the Republic. This demand increased during the Napoleonic Wars, and during the first decades of the nineteenth century the town boasted of twelve tanneries employing sixty men.

The next hundred years saw a gradual expansion of the leather industry, interrupted only by the brief periods of economic depression which overtook the whole of Europe during the 1820s and 1840s. Despite these, the tannery of Placide Peltereau (the direct descendent of Bernard of 1543) was confident enough in 1844 to invest in a steam engine and associate machinery. Twenty five years later, the main line railway between Paris and Tours was built, passing through Chateau Renault. This gave rapid access to the West coast ports for raw materials and to the capital and its dominant markets for finished leather.

The last twenty years of the nineteenth century saw the pinnacle of prosperity for Chateau Renault and its tanning industry. By 1890 there were sixteen tanneries, three tanbark mills, three shoe factories, two glue and gelatine factories and numerous small currying shops and independent handcraft shoemakers. The whole of the lower town consisted of an almost uninterrupted string of factories along both sides of the river banks, each fronted by imposing offices and the houses of the master tanners. Contemporary photographs show, from the number of tall chimneys, that each factory had one or more steam engines to provide the necessary power. They also show cartloads of oak bark, hides and finished leather being hauled along the stone paved streets by powerful horses. Records indicate that from a total population of just under four thousand at this period, over one thousand persons were employed in the tanning and related trades.

Although the nineteenth century saw a series of changes in the tanning industry, the introduction of new vegetable tanning materials,

the use of extracts, the inception of counter current liquor systems, etc, the majority of the tanners of Chateau Renault continued to employ time-consuming traditional methods using only oak bark in layaways. These, they felt, gave a superior product, esteemed throughout the world. This impression was reinforced by the increasing number of tanners from other areas claiming to make leathers 'like Chateau Renault'. In order to protect their reputation, a Union of Tanners was founded in 1885 and two trade-marks were registered. An independent agent was appointed whose responsibility it was to inspect all the tanyards and to stamp all finished hides to certify that they had been in the tan pits for the declared period and were of a guaranteed quality. These trade marks are still being used to this day by the one tannery still producing pure oak bark tanned leather.

The increasing use of rapid methods of vegetable tanning employing imported tanning materials, the introduction of competitive synthetic materials for transmission belting and shoe soling and, above all, the chrome tanning process all had their impact on the leather industry of Chateau Renault. Just as the nineteenth century saw a steady expansion, the years since 1920 have been ones of gradual decline. Since 1925, over twenty tanneries have closed down. In 1954 the direct successor of the tannery founded in 1543 by Bernard Peltereau was shut, followed, in 1978, by that started in 1597 by his relative.

It was the realisation that hundreds of years of tradition were disappearing almost overnight that led a small band of local enthusiasts in 1978 to set up the Tannery Museum.

At present the exhibits are housed in the ancient storeroom of the twelfth century castle. The visitor descends a twisting stone stairway and enters through a massive door into a large, well lit chamber. Here, the traditional processes employed by the tanners of Chateau Renault are explained. The exhibits are illustrated by old engravings and actual examples of the hand tools used. Of particular interest is a special type of fleshing knife thought to be unique to this area of France. It resembles the knife depicted in a thirteenth century stained glass window in

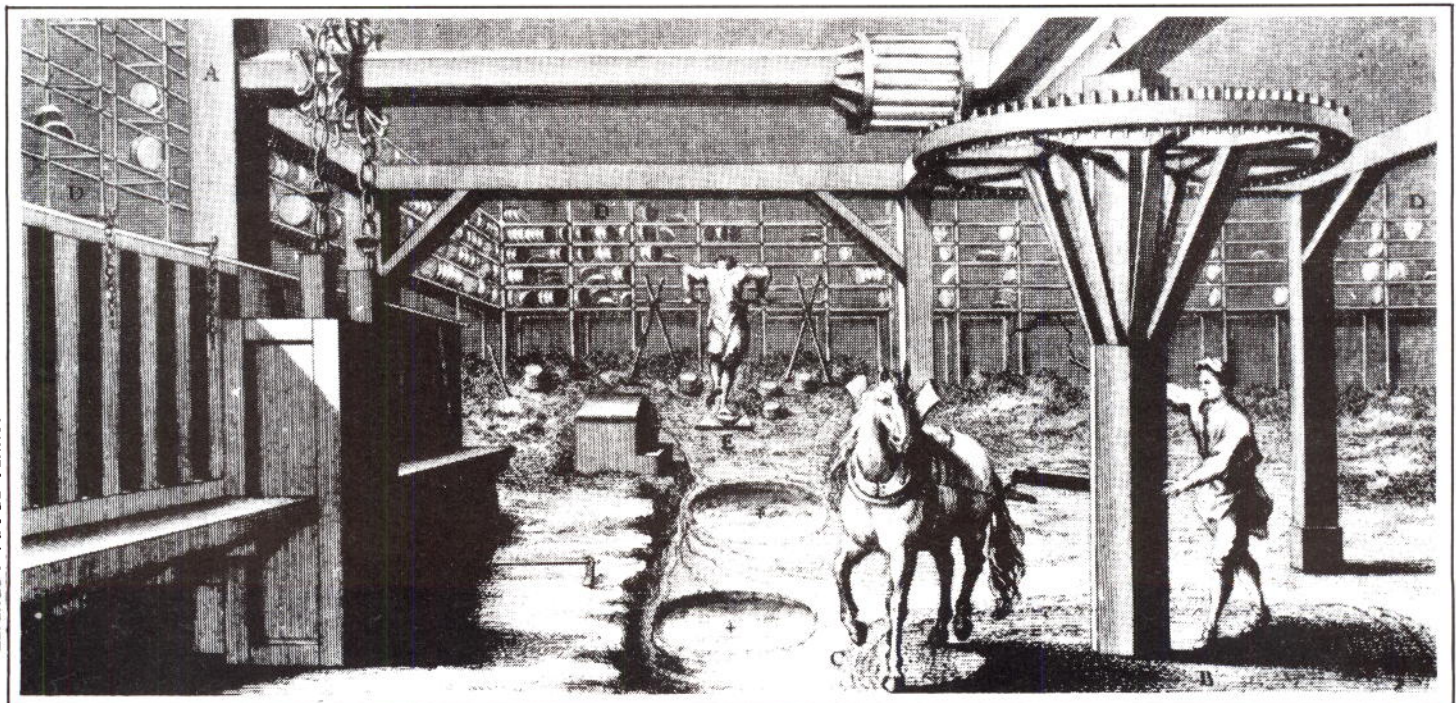

From Lalande's 'Art du Tanneur'

Chartres Cathedral. A series of maps shows how the industry dominated the town in the late nineteenth century and these are highlighted by a series of photographs taken between 1890 and 1910. Copies of these photographs and of the Museum's Bulletin are displayed for sale.

Last year, the Museum was given the use of a complete late nineteenth century tannery site. This includes the stretch of river bank from where the hides were washed in the running stream, the limeyard, the covered handling pits, over 200 layer pits, a series of drying sheds fitted with louvres, two four-storey carrying sheds, the boiler house and engine room and all the associated offices, stables, coachhouses etc.

The exciting task the Museum has set itself would appear to be enormous. They are determined to restore the tannery site, to make a collection of tanning machinery and to transfer the exhibition, showing the changing story of the leather industry through the ages. The enthusiasts point to the undoubted success of other industrial museums across the world, and have the encouragement of the local authorities and the tourist board. Let us hope that it is not too long before the Museum makes Chateau Renault once again famous throughout Europe as the 'City of Leather'.

Roy Thompson

This article was originally published in the *Newsletter* of the Northampton Industrial Archaeology Group.

A Note from Italy. The **Italian Society for Industrial Archaeology** (SIAI) has begun publishing a new journal titled '*Archeologia Industriale*' focused on the experience of documenting and studying our industrial past. It is a joint venture carried on with two Foundations (the Micheletti Foundation, Brescia, and the Feltrinelli Foundation, Milan) specialising in labour history and very active in their field. The journal, which is planned to have summaries in English, will be issued three times each year, subscriptions must be addressed to: Luigi Micheletti editor, at Temistocle Solera 51, 25100 Brescia (Italy). The annual subscription is 15,000 Italian Lira (about £6.50).

The Italian scene in industrial archaeology in recent times has had new interesting improvements particularly concerned with the public organizations. Regional Government of Lombardy is going to support the second stage of a survey documenting hundreds and hundreds of sites, the publication of the results and of a poster to be sent to schools and libraries illustrating aspects of our industrial heritage. The Regional Government of Abruzzi has organized a travelling exhibition which has been very successful in terms of the public and press. A major bank is supporting the publication of a three large format volume series titled '*Archeologia industriale in Lombardia*' providing a comprehensive view of the industrial heritage of that region. Also in the academic field one could observe interesting results and an increase in interest towards the subject: a good test is provided by the presence of 16 university professors (each one in top position) in the Scientific board of the new journal. A problem which has aroused in the most recent times is the problem of some legislative initiatives which could make easier to protect industrial monuments at present left to the local and individual sensitivity about their value. Other aspects of

the debate concerns industrial museums of which Italy is particularly poor. Facing complex problems like the mentioned above requires gathering individual forces interested under different points of view in the field, not only industrial archaeology enthusiasts but also government officers, museum curators, university people, and so on.

That's one of the main targets of industrial archaeologists in Italy at present and the first results seem to be rather good although difficulties and obstacles (as usual) are so numerous and hard to cope with.

Massimo Negri

Tool and Trades History Society. Tools are arguably the most significant of man's artifacts, yet they receive the least serious attention. Museums are full of weapons, pots and jewellery but displays of tools are still rare innovations.

When tools are admired and collected it is too often as quaint relics, or even as 'sculptural forms' — a recent exhibition was entitled 'The Tool as Object', and axe-heads have been displayed as examples of abstract art! Little attempt has been made to study tools as a subject in their own right and, by understanding their function, to gain insight not only into the techniques by which all other artifacts were produced but also into the lives of that large proportion of the population which, throughout the ages, has been engaged in making things by use of hand and tool. Even recent works by archaeologists, and historians of many technology-based subjects like buildings, furniture or boats, either ignore the practical technicalities of production or uncritically accept folk-lore as fact.

The Tool and Trades History Society is being founded in response to the need felt by a growing number of enthusiasts for a forum in which to share and enlarge their common interest in tools and techniques. Some started by admiring tools and then went on to ask how they were made, how they were used, when and why. Others

are working craftsmen who feel the urge to investigate and record the origins of their trade.

Documentary evidence is not easy to find as most trades insisted that knowledge and skill, their 'mysteries', should be passed on only through the personal link between master and apprentice. However there are many sources of indirect evidence, as, in art, the development of language, and the traces left by tools on the materials worked. Then there is the direct evidence of the tools themselves which have survived, sometimes unrecognised, in vast quantities from earlier centuries.

However, some at least of the founders nurse hopes that the Tool and Trades History Society will do a little more than satisfy the needs of its own members. They see an important educational role which should operate in two directions. On the one hand it should increase interest in pre-industrial tools and technology among museum staff, specialist historians and, in particular, archaeologists. (To demonstrate the present situation look in the index of any general work on archaeology and compare the entry under Tools with that under Weapons.) On the other hand it might help in raising pride and interest in craftsmanship. In France and other countries the craft-guilds are seeing a considerable revival, often with government encouragement. Basing themselves on historical tradition they do much to create pride and high competence in all those trades which require manual skill. If TATHS could make some contribution, however small, in this direction, it would be more than justified.

Further information from: Philip Walker, Winston Grange, Debenham, Suffolk. Tel. Debenham 860441.

Working Holidays. Groups who can offer opportunities for volunteers to come and work for short or long periods at their projects should send information to the Central Bureau for Educational Visits and Exchanges, Seymour Mews House, Seymour Mews, London W1H 9PE. This information can be published in their

'Ruth' the 1925 steam roller by Marshall Ltd on loan from West Sussex County Council, seen on arrival at the Chalk Pits Museum on April 17th.



annual publication 'Working Holidays' free of charge and should attract people to assist in your scheme.

Grants from the Department of the Environment.

During recent years, encouraged by the campaign launched by the Rescue group, the Department of the Environment has provided a great deal of money for traditional archaeology. This has not been matched by support for industrial archaeology. Grants have been given for survey, for excavation and for post-excavation reports, and in allocating the money available, the DoE have had regard for the recommendations of local committees.

Southampton University Industrial Archaeology Group have made two applications for grants, the first for survey work on the site of Bursledon Iron Works, and the second for survey and excavation of a water power installation at Brownwich Farm, near Titchfield. The policy of the DoE is to confine the allocation of grants for post-excavation reports to those sites which have already received DoE money for survey and excavation. Only modest sums were required for our initial work on these sites, but assistance for publication of the reports was urgently needed, and it would appear that the chances of getting one without the other are very limited. Our applications were supported by the Hampshire Archaeological Committee and the Wessex Archaeological Committee, and both were unsuccessful. We should very much like to know of the experience of other industrial archaeology groups which have made formal application for grants from the DoE.

Edwin Course

Westonzoyland Engine Trust. On the 19th of August this year life once again flowed through the Easton and Amos Drainage Machine housed at the Westonzoyland Pumping Station on the Somerset Levels. The Machine was built in 1861, and consists of a twin cylinder vertical steam engine with two 'A' frames supporting the crankshaft. The flywheel, which is situated in between the 'A' frames and to one side, drives from its rim a bevel gear on a vertical shaft held by an onion bearing, on the bottom of which is hung the pump impellor in a 15' deep well beneath the unit. Also in steam that day was a horizontal engine made by the local firm of W & F Wills of Bridgwater. It was built in approximately 1896, and used to drive a pug mill in a local brick and tile works. It is the only known

surviving example made by the firm, and incorporates their patent poppet valves, camshaft operated double beat.

In front of an invited audience, the Drainage Machine was started by Mr Wally Musgrave, the last of the steam pumping station attendants on the levels. After the ceremony there was a little liquid refreshment (!) and entertainment from a local jazz band.

Having achieved only the first of its aims, the Trust now hopes to raise sufficient finance to pay for the repairs to the station building itself, which is in a state of delapidation after almost thirty years of neglect. The first stage in this will be the erection of a workshop building on the site, which will also house a collection of vintage workshop machines, and one of the Crossley Diesel engines from nearby Durlough Reservoir. **(AIA Swapshop 1983/2).**

Open days for 1984 will be on January 1/2, and thereafter on the first Sunday afternoon in every month, April to October inclusive, from 2 - 5 pm. The station is situated 1 1/2 miles from Westonzoyland village centre, along the side road to Burrowbridge. NGR ST 340328.

Take an area chock full of industrial remains, most of which are situated in outstandingly beautiful surroundings, add a handful of knowledgeable IA enthusiasts able and willing to show visitors round and the biggest problem is usually accommodation. Not so in the case of a weekend on **IA in the Forest** planned for next spring, for the Littledean House Hotel, near Cinderford in the Forest of Dean is managed by another industrial archaeologist/local historian, **Josephine Felton.**

Mrs Felton is a member of the **Friends of the Dean Heritage Museum** and spends a lot of her spare time helping with the many chores which abound in this dynamic undertaking. She had however wondered for some time whether she could combine her professional life with the IA scene and thus enable others to enjoy the district of which she is so fond. Getting together with **Ian Standing** and **Stan Coates**, two local IA lecturers solved the problem and now she is all set to go, over the weekend of March 30th to April 1st 1984.

After a Friday evening introduction to the area by Ian Standing, **The History of Dean and its Industries**, there will be two days of guided tours interspersed with a further lecture (Saturday

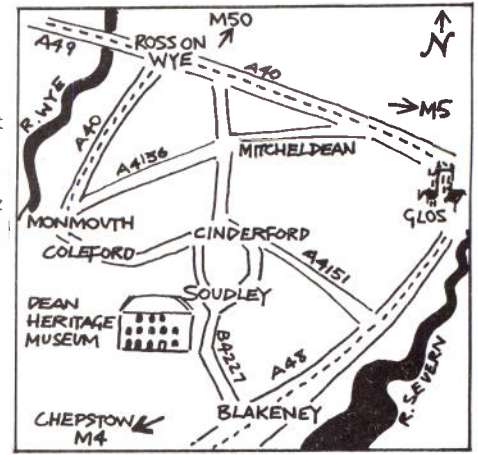

evening) by Stan Coates on the **Angidy Valley, Tintern**, famous for nearly 350 years of wire making. Places to be visited during the weekend will include: Darkhill Ironworks, Whitecliff Blast-furnace, Clearwell Caves and mining museum, Bickslade Valley and of course the Angidy Valley.

All meals (packed if appropriate) transport, entrance fees and accommodation will cost £45 fully inclusive and enquiries should be made to Mrs Felton at the Littledean House Hotel, Cinderford, Gloucestershire GL14 3JT, telephone Dean (0594) 22106.

Limekilns was the theme of the Dartington IA one-day conference held on Saturday 8th October at the Devon Centre for Further Education organised by the Exeter IA Group and Professor Walter Minchinton. It was a day of constant delight held in the gracious surroundings of Dartington Hall near Totnes. *'Limekilns tend to be ignored by quite a few people'*, said one speaker, *'if they think of them at all, they assume that having seen one, they've seen the lot. They're all alike'*. Well, this may be a general view, but it is quite wrong as shown by the Dartington speakers.

After a brief introduction by Walter Minchinton, who put 'lime-burning' in Devon (15th C to mid-19th C or until 'lime-grinding' took over) in an economic history perspective, and Stan Punched (a retired farmer) who described and illustrated the geological locations where the greatest concentrations of lime-kilns occurred, David Drewer, a Paignton headmaster showed a few examples of the 30 kilns he had located in Torquay and some of the 119 he has discovered so far, in adjacent parishes.

Cynthia Gaskell-Brown, Keeper of Archaeology at Plymouth City Museum, took as her demonstration area the Tamar Valley, above Calstock, and in particular the Lime-kiln complexes at New Quay and Morwellham. In contrast to those in Torbay the New Quay kilns were, and still are, although largely hidden by dense vegetation, quite massive (by Devon standards) and serviced by a sophisticated arrangement of loading platforms and tramways. All four of the morning sessions were thus given by speakers from the host county and the after-lunch period was given over to visitors from outside Devon.

Eric Taylor from BIAS described a few of the 177 lime-kilns he had located in Avon and included a very evocative slide of the last kiln known to have worked in the county, that belonging to Keeling Brothers of Keynsham which was shown during a working session glowing with small coal and partly converted blue lias limestone. Eric's job takes him regularly into quarries in South Wales

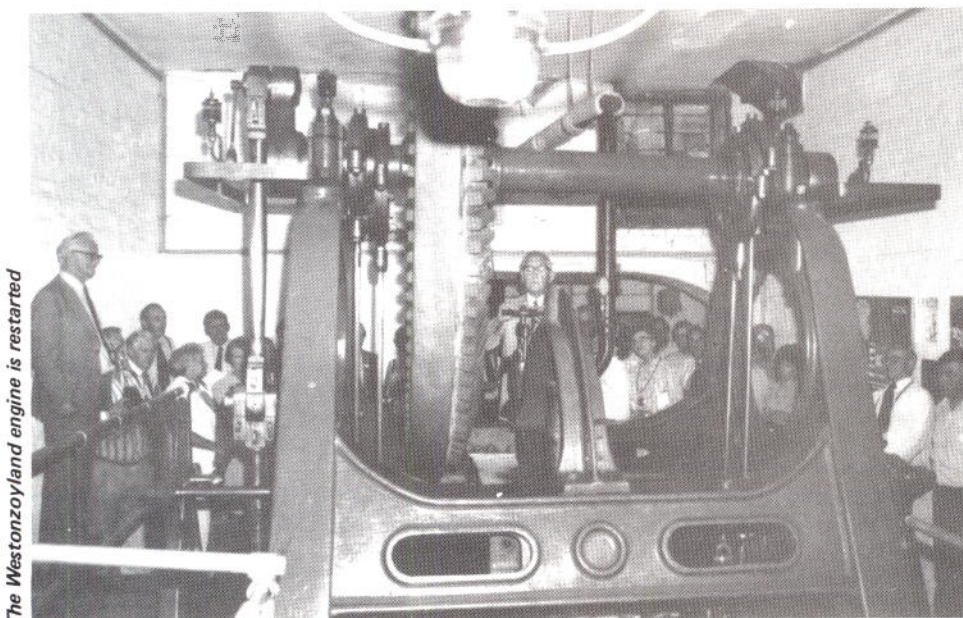

The Westonzoyland engine is restarted

and he concluded with a series of slides showing a lime-kiln near Llantrisant which has recently been re-lit to produce lime for the local iron and steel industry.

A trio of speakers from SIAS (the Somerset IA Society) dealt with kilns from all corners of this admittedly large county, a few of the 500 which Brian Murless claimed had been identified. Sandy Buchanan and Derek Warren also gave comments describing kilns from as far apart as Evercreech (near Shepton Mallett), Dunball, near Bridgewater Minehead, Steep Holm (an island in the Bristol Channel) and Taunton, showing a delightful picture of a defunct lime-kiln on top of which the GWR (as it was then) had erected a water-tank.

Tony Jukes (Oxford House IA Society, Risca) first gave a practical demonstration of the power of calcined limestone in heating a beakerful of water and then an illustrated excursion round the coastal lime-kilns of 18th and 19th century Pembrokeshire from Newquay and Fishguard to Tenby, combining this with abstracts from Port-books and a series of maps and diagrams showing the decline of the small agricultural lime-kilns once the railway network made larger units a viable proposition. David Bick, representing the GSIA described limekilns in the vicinity of Newent, Glos which were of massive and quite unusual construction. David's slides also showed an object lesson in extempore excavation techniques. Faced with the usual infil of soil and debris plus his insatiable curiosity to know what was between the mouth and the eye of the kiln, he commandeered a couple of ladders and a bucket and with typical Bick-like ingenuity, constructed a bi-pod to enable the kiln shaft to be cleared, measured and drawn.

Michael Messenger is primarily interested in transport history spiced with excursions into financial matters (as befits the AIA treasurer) and he gave several examples of lime-kilns which had been built as speculative ventures and several more where interesting remains, easily overlooked by less expert observers, remained as memorials to the ingenuity of the builders of inclined-planes, tramroads and esoteric devices aimed at getting raw materials to, and finished lime from, kilns. The final contributor to a memorable day was Martin Watts who most people will know as a practical miller and enthusiast for wind and water powered machinery. Martin showed photographs of a water-wheel powered lime-kiln winch at Moorswater

on the East Looe River where a water-wheel provided the power to pull truck loads of limestone and culm up a ramp to a turntable on top of a pair of kilns. Martin and Peter Stanier have measured up the complex and two of his details are shown below.

Around forty participants enjoyed their Dartington IA day and now know, that far from being the same, all lime-kilns actually tend to be different, only some are more different than others. There will be another Dartington IA Day in 1984. It will be held at around the same time, early October, and will be devoted to Turnpike roads and road-side furniture of all shapes and sizes.

Castlefield Urban Heritage Park, Manchester.

Britain's first Urban Heritage Park has been established in the Castlefield area of Manchester. After years of neglect the physical remains of the industrial revolution are being rescued and refurbished to provide a unique complex of museums, visitors centre, exhibition hall and hotels — all set in an environment which provides magnificent material for studies in industrial archaeology and local history.

The Air and Space Museum has already opened in the former **City Hall** (a Grade II listed building of iron framed construction with glass infill, over one hundred years old). The Museum is the result of co-operation between the Manchester City Council and the Royal Air Force Museum at Hendon and the vigour with which the project has been pursued mirrors the confidence behind the whole Castlefield scheme. Manchester's links with aviation go back to the early days of the century, particularly the firm of A V Roe whose first factory still stands in Manchester (Brownsfield Mill, Ancoats). Although it has not been possible to place among the exhibits a Lancaster (made in great numbers during the war at Chadderton), the ancestral line of that famous four-engined bomber is represented by an Avro Shackleton AEW 2. The magnificent display of aircraft includes Supermaine Spitfire Vb, Roe Triplane replica, Hawker Hunter F4, Avro 707A, De Havilland Vampire FB6, Cayley Glider replica, English Electric P1A, Newbury Eton Glider, Bristol Belvedere HC.1, Avro Avian, Miles Magister, Scottish Aviation Pioneer CCI, Kugisho Ohka and a Bristol Sycamore HR14.

In September 1983, the first phase of the Greater Manchester Museum of Science and

Industry will open in the restored **Liverpool Road passenger station**, a Grade I listed building, originally the terminus of the Liverpool to Manchester Railway and the oldest surviving passenger station in the world. The exterior and interior of the station building have been renovated to their original condition and will house a display illustrating the history of the Liverpool — Manchester Railway. Other buildings on the site being renovated include the 1830 Warehouse (Grade II listed), the 1860 LNWR goods warehouse, and the Byrom Street warehouse. The Museum will accommodate the exhibits of the present North West Museum of Science and Industry, to be transferred from the present inadequate and cramped quarters in Grosvenor Street and at a number of other storage sites scattered about the region. The first major exhibition area in the new Museum will be in the former **1860 LNWR goods warehouse**. Known as the Power Exhibition Hall, it will tell the story of industrial power. Many of the exhibits have been built in the Manchester area — Crossley, Gardner and Rolls Royce engines, Beyer Peacock locomotives, and electrical generators by Mather and Platt, Ferranti, and Metropolitan-Vickers. Adjacent to the Power Exhibition Hall, lengths of rail track, connected to the main line system of British Rail, will allow trains and steam engines to make short journeys for passengers. A recently refurbished overhead crane gantry forms a striking feature here.

After years of uncertainty and procrastination, the redevelopment of **Central Station** (opened 1880, closed 1967) is well under way. The splendid train hall with its single span overall roof of segmented steel arches cantilevered out from the side walls (the second largest span in Britain) is being converted into an exhibition centre and indoor arena of 10,000 square feet. Opposite is the **Midland Hotel** (1898) recently purchased from British Rail by the Greater Manchester Council. The other major building on the site — the massive **Great Northern Railway Company's goods warehouse** (1897) — with its ribbed steel frame and concrete floors, is to be converted into a 4/5 star incorporating a sports and leisure centre. These developments will ideally complement what is going on in the Castlefield conservation area barely one quarter of a mile away.

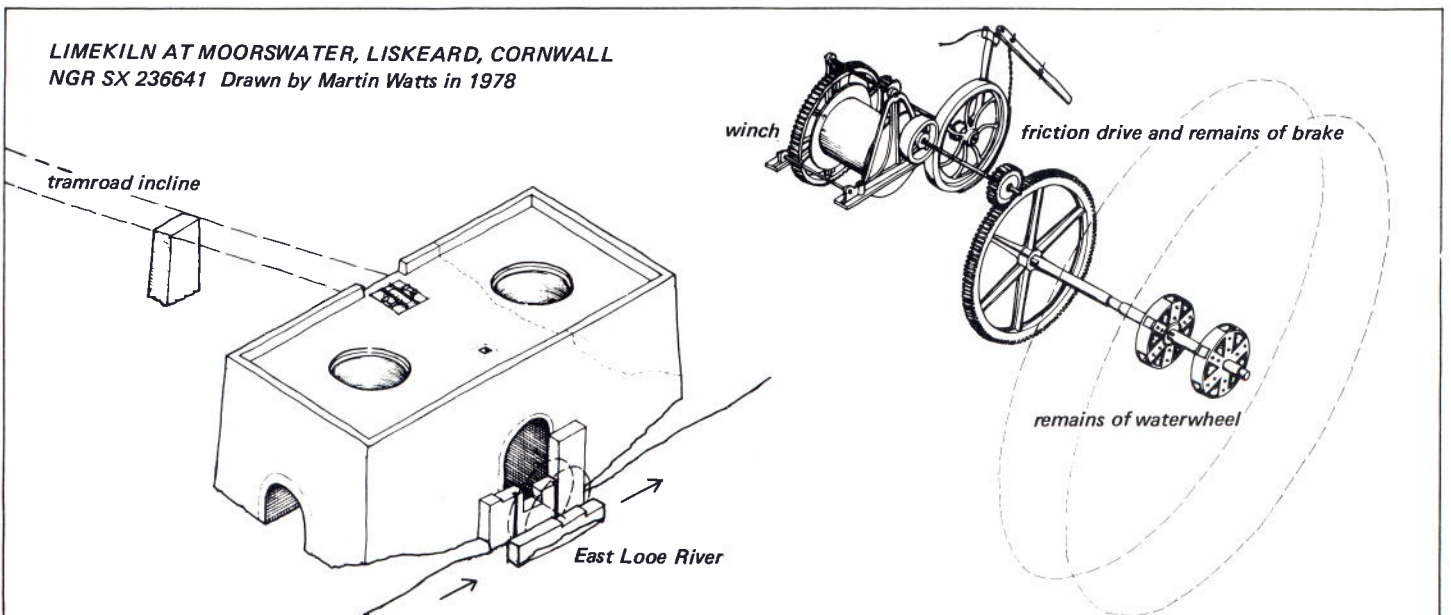

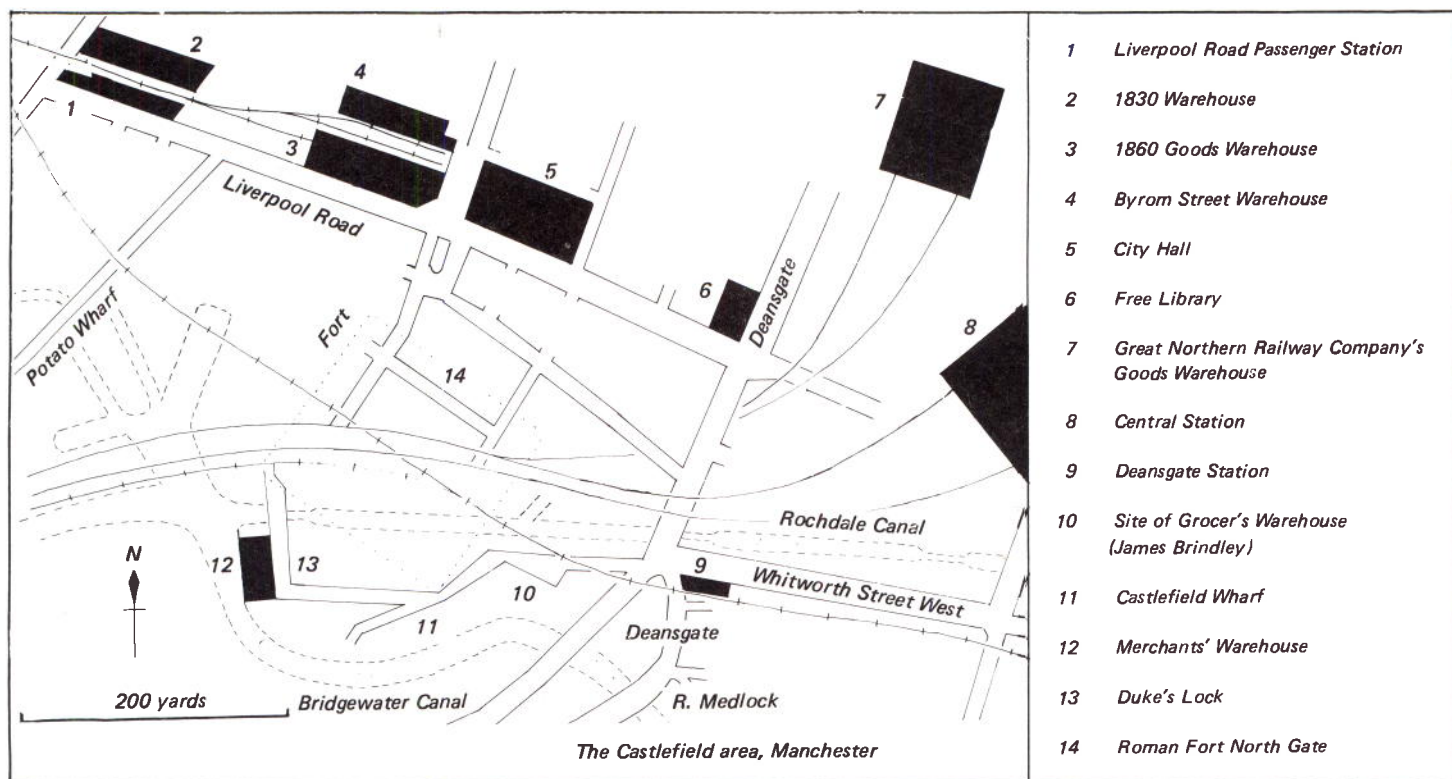

The **Roman Fort** of Mamucium occupied a natural site on the edge of a red sandstone crag between the confluence of the River Medlock and River Irwell. The north gate stood only a few yards from the present Liverpool Road opposite the Air and Space Museum. Excavations here since the 1970s revealed a civilian settlement and industrial township, defence ditches, fort walls and a roadway leading to the north. The area has been landscaped into a grassed open space and a reconstruction of the north gate has been built – with a rather incongruous effect, some would feel.

The remains of the fort were obliterated when the canals and railways were built. The Victorian engineering of the railway viaducts and bridges is very impressive at Castlefield, particularly the decorative ironwork and massive iron pillars. There are four separate lines to distinguish here:

- 1 Manchester, South Junction and Altrincham Railway 1849.
- 2 Former line into Central Station 1877.
- 3 Former line into the Great Northern Railway Goods Warehouse 1898.
- 4 The South Junction line (which goes under all the previous ones) from Castlefield to Ordsall Lane and which joins the original Liverpool – Manchester line at the River Irwell.

All this provides marvellous material for the study of historical development and industrial archaeology of this part of Manchester, particularly, when one adds the Liverpool Road station site and museums.

Further fundamental studies in transport history and the early industrial revolution are provided by the **Bridgewater Canal** (1859) and **Rochdale Canal** (1805) and associate physical remains. There cannot be many areas in Britain where such a rich residue of an industrial heritage is to be found in such a small area.

The opportunities for education are being met by the establishment of a Visitors' Centre in the former **public free library** (1882), another

renovated building in the corner of Liverpool Road and Deansgate. This will also house the Manchester Education Committee's Urban Studies Centre which provides guidance, resources and well researched trails for students of all ages.

The tourist potential of the Castlefield area has lain latent for many years. Now, imaginative marketing is required to promote the development of the museums, and the refurbishment of the buildings and other physical remains. To this end, only recently, discussions have taken place with the English Tourist Board to co-ordinate a marketing policy on the American park theme which will encourage visitors to spend days rather than hours on visits. The Castlefield Urban Heritage Park will revitalise this part of Manchester and re-affirm nationally and internationally the industrial heritage so long neglected.

*Derek Brumhead
North Hulme Centre, Manchester*

Preservation of Liverpool's Georgian Legacy.

The North West Civic Trust are pleased to announce the commencement of the first phase of street improvement schemes for three important terraces of listed buildings in Everton, Liverpool. The first phase comprises 47-71 Everton Road, situated within the Erskine Street Environmental Improvement Area, Liverpool 6. The scheme will be grant aided by the Department of the Environment through the Liverpool Inner City Partnership Urban Programme.

The grant aid follows an initial feasibility study carried out by the North West Civic Trust for Liverpool City Council to appraise the practical and administrative implications of potential street improvement projects for three blocks of properties in Everton Road and Shaw Street.

All these terraces are typical, in terms of design and construction, of the originally substantial stock of sophisticated Georgian brick built housing constructed in the early part of the 19th century and associated with Liverpool's commercial hey-day. Subsequent social and economic changes have resulted in the

general neglect of these terraces, but they remain basically sound structures with considerable potential.

In the short term the project will safeguard the structures and secure a major visual impact. In the longer term it should also increase the confidence of owners and potential investors in the future terraces, leading to new investment, better standards of maintenance, and a renewed life for the buildings. The works will comprise the comprehensive restoration of the street facades and roofs of these properties, including the reinstatement of all defective and lost building elements.

Sensitive and effective restoration is required, not only to ensure the preservation of an important remnant of the City's Georgian legacy, but also to serve a useful future term of life as an essential part of the social fabric of the Environmental Improvement Area.

The North West Civic Trust is an independent environmental charity concerned with promoting excellence in our environment, and providing a better place in which to live and work. It is currently involved in the Bold Street Improvement Scheme, Liverpool together with the properties on the corner of Church Street and Ranleigh Street which have already brought a dramatic visual improvement to the area.

Bury Firm cast Reproduction Shaft for Restored Water-wheel.

A Bury firm of paper machinery makers has used modern foundry and machinery technology in a restoration project on a mill which dates back to the industrial revolution. Craftsmen from Beloit Walmsley were called in to Quarry Bank Mill, Styal, Cheshire, to see if they could cast a water-wheel shaft. The former cotton mill has been restored as a working museum.

The huge water-wheel, measuring 32 ft in diameter and 21 ft wide, produced 100 hp for the mill's 305 looms, and was the power source for the cotton manufacturing process. It was built at a cost of £7,736 in 1819 and increased production by 150%, and remained in operation until 1903 when turbines were installed.

Mr. Stanley Tudge, casting sales manager for Beloit Walmsley said 'The original shaft could not be repaired, and another one had been found but was not suitable. We had to make our own drawings by taking measurements from the old shaft, as there were no original plans available. Once it had been cast we were asked to produce a new spoke housing as the existing one was beyond repair. It was a very difficult job because the spokes come out at different angles'.

'After completion' he continued, 'the shaft and spoke housing will be stored outside and allowed to rust to bring them back into character with the existing parts of the wheel'.

Once the wheel is complete it will provide power for old textile machinery on display inside the museum.

Quarry Bank Mill was built in 1783 by Samuel Greg, the son of a Belfast ship owner, on the edge of the River Bollin when water was the main power source for cotton mills. At its height the company operated 4,000 looms and employed more than 2,000 people at six factories throughout the North West, including one at Bury.

This article originally appeared in the *Foundry Trades Journal*.

The AIA are introducing a new service aimed at making more generally known, the considerable amount of news and comment which appears in newspapers and the specialist press on IA matters. Called the **AIA Abstracting Service** it will depend entirely on you, the ordinary member, who is being asked to make a brief note of that interesting item you have just read in, say, *Country Life*, *The Guardian*, or *New Scientist* etc in order that:

- (a) it can be filed and be recalled,
 - (b) the information can be brought to the notice of other people who are interested in the subject.
- Standard forms are available, an example is shown below, and these can be obtained from John Powell at the Ironbridge Gorge Museum Library. It is hoped that readers of the Bulletin who regularly scan other informed publications will take the trouble to complete an **Abstracting form** and return it, either singly or in a convenient sized batch, to John. The form is printed on NCR (no carbon required) paper which will enable a copy to be retained by the contributor. The Abstracts will then be sorted, tabulated and published, either in the *Review* or the *Bulletin*.

Newcomen Branches. The Newcomen Society for the Study of the History of Engineering and Technology celebrated its Diamond Jubilee in 1980. The services which the Society can offer its members fall into two broad groups. Through its publications, and particularly through its widely-quoted and respected transactions, it disseminates all over the world the results of members' researches. And for those who live within travelling distance of London, it has for many decades held monthly meetings during the winter months, usually at the Science Museum in South Kensington but occasionally at the premises of other learned societies and professional institutions, where audiences of about one hundred gather to hear papers and discuss them. All members receive *The Newcomen Bulletin* three times each year, edited by John Boyes. Details and application forms from Ian McNeil, Executive Secretary, The Newcomen Society, The Science Museum, South Kensington, London SW7 2DD, tel. 01 589 1793.

For those living outside the London area, the only point of contact with other members has for long been the Society's annual summer meeting lasting 4-5 days, devoted principally to visits to industrial sites and monuments in a particular area. In order to maintain more regular contact between members, the Society's Council has encouraged the formation of regional branches. One such branch has flourished for several years in the Midlands, based on the Birmingham Museum of Science and Industry with Charles Blick as the energetic Branch Secretary. Charles has since handed over secretarial duties to James Andrew from whom further details of Branch activities are available at 64 St Agnes Road, Moseley, Birmingham B13 9PN. In 1979 the Stephenson commemorative festivities in the North East provided a suitable focus for the establishment of a North-Eastern Branch, and further details of its activities are available from Robert Rennison, BSc, MICE, 25 Graham Park Road, Gosforth, Newcastle on Tyne NE3 4BH.

More recently, a North Western branch has been initiated through the efforts of Dr Richard Hills of the North West Museum of Science and Industry, Dr J O Marsh and others in the Manchester area. A programme of Branch activities has been drawn up and a bulletin launched. Further details can be obtained from J O Marsh MSc, at Department of History of

Science and Technology, University of Manchester Institute of Science and Technology, P O Box 88, Manchester M60 1QZ.

The Historical Association — with over 8,000 members sharing a common interest in history — is set to launch a new magazine for members — *The Historian*.

In addition to historical articles, features and HA news, this magazine will be publishing information about activities of interest to members being organised by other bodies — for example courses, conferences, exhibitions, outings and festivals. This well-illustrated magazine will take the place of our members' newsletter *The Kennington News*, and we hope that AIA members will take this opportunity to publicise their activities. Even if lack of space prevents inclusion the information will be kept on file and available to individual enquirers.

The magazine will be published three times a year. Please give us plenty of time and submit your information as soon as possible to the Secretary, The Historical Association, 59a Kennington Park Road, London SE11 4JH.

Letters to the Editor

Arthur D Dunn, a longstanding Canadian member of the Association for Industrial Archaeology has written to us on the subject of machine tools. His address is 1287 Castlehill Crescent, Ottawa K2C 2B2, Ontario, Canada and members with any information should contact him direct.

Dear Sir

I would appreciate your assistance in providing some assistance. I am taking over the editorship of Tools and Technology, an organ of the American Precision Museum in Windsor, Vermont. Tools and Technology is founded upon the development of the machine tool, and the museum in Windsor is located in the former factory of Robbins and Lawrence, manufacturers of rifles and the makers of the ancestors of the famous Winchester rifle 'that won the West'.

This plant also made 'Enfield' models for the British Government of which 25,000 were made for the Crimean War, and produced the machine tools to equip the Enfield Works, near London, for the manufacture of interchangeable parts of weapons during the mid 19th century.

The Museum has a very interesting collection of machines, some of which are quite unique, and is located in a very picturesque part of Vermont, probably one of the prettiest states in America.

Tools and Technology is generally based upon American machine tools, but as the machine tool is not an American device, it also had a pre-history, and will in future include anything that relates to the history of machine tools. Comments appropriate to this basic premise will be appreciated from AIA members. Photographs of equipment and tools, and the technology involved would also be appreciated.

Sincerely
Arthur Dunn

AIA Abstract		Subject	<i>Oldest Electric Railway.</i>
Title	<i>'Old Volk's home for bright sparks'</i>		
Author	<i>Mick Hamer</i>		
Publication	<i>New Scientist</i>	Volume	<i>97</i> Number <i>1374</i> Date <i>8 Sept 83</i>
<i>Commemorating the 100th anniversary of the opening of Volk's electric railway at Brighton, 4th August 1883, the oldest of its kind. Reference to contemporary account in London Daily News.</i>			
		Submitted by	<i>Jon Day</i>

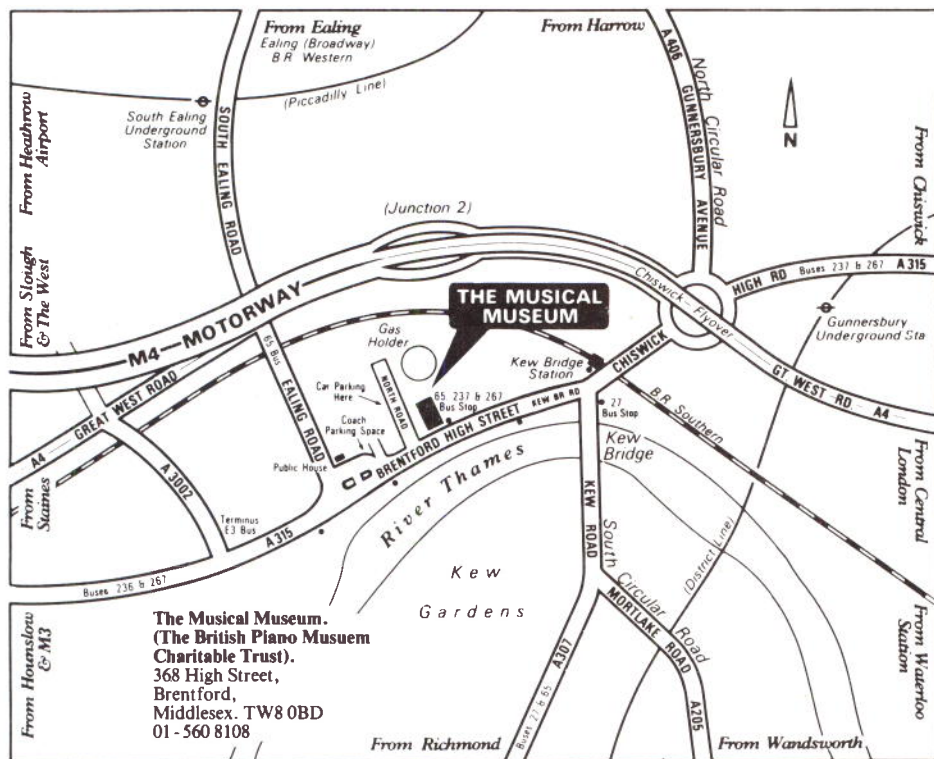

The Musical Museum. 1983 marks the 20th Anniversary of the founding, by **Frank W Holland**, of the first museum in Britain and probably in the world, devoted mainly to automatic musical instruments, and in particular to reproducing pianos. These pianos can give an exact reproduction of the performance of a famous pianist recorded over 50 years ago. The recording is captured on a paper roll, but as there are several different systems to do this, it would be difficult to find them all under one roof. You can at Brentford. To mark the 20th anniversary 10 reproducing systems have been fully restored.

There is also a large collection of other unique instruments to hear including a Foto-player, a precursor of the Cinema Organ.

Other special events this year include:

An Exhibition of items from our scrapbook which traces the history of the collection and the events which have made it one of the finest in the world.

A special Exhibition of our collection of unusual, unique and beautiful non-player pianos. These include decorative instruments for the Exhibitions of 1851, 1862 and 1939, double keyboard pianos a cinema piano/organ, and some very early pianos including Broadwood and Clementi. This Exhibition is located nearby the Museum but is only open by special arrangement.

In September a Convention of all Player Piano Groups was held at the Museum. Frank Holland was the Founder of the first group in 1959.

A special bust of the Museum's Founder was made, and is now displayed at the Museum.

All these events are, of course, in addition to our regular demonstration tours every weekend afternoon April – October, Wurlitzer concerts, and special music roll concerts.

1983 is for us a special and busy year.

John E Taylor

PSA Historic Buildings Registered. The Property Services Agency which is part of the Department of the Environment, have published Volume 1 of their *Register*. This covers Northern and Eastern England, the Midlands and Wales. A soft-back publication, it is of 170 pages and profusely illustrated in colour and the cover photograph is of exceptional quality. It includes a description and photograph of every historic building occupied by the Property Services Agency together with details of listing etc. The publication is priced at £10.00 and is obtainable from the Property Services Agency C Block, Whitgift Centre, Croydon CR9 3LY.

Stoke-on-Trent Historic Buildings Survey of all the surviving buildings in the City from before 1922 is nearing completion. The archive consists of approximately 10,000 record-cards and associated photographs, referring to some 50,000 structures. In addition nearly 200 buildings have been surveyed in detail and measured drawings prepared. These buildings are representative of the whole range of 19th century factories, housing, chapels, schools, etc. and include the 48 surviving 'bottle-ovens'.

The Survey is based at the City Museum and Art Gallery, Stoke-on-Trent and is financed by the Manpower Services Commission, employing 27 people at the present time. The archive is available for use by interested persons. A publication of the results is projected for 1984-5.

Anyone interested in the Survey may contact: C F Hawke-Smith (Stoke-on-Trent 29611).

Tanyard Building at Amberley Chalk Pits Museum. On June 14th the recently erected Tanyard Building was opened by Lord Montagu of Beaulieu.

This building was moved to the Museum from Horsham, having stood in the former County Council Depot in Brighton Road for over 100 years.

It is largely of cast iron, and was made in London in 1842, and first erected in the Bermondsey area of South-east London. In about 1880 it was dismantled and transported to Horsham for re-erection and continued in use

as a tanyard building. The Museum was able to rescue the main components of the building and to reconstruct them at Amberley, using Grant Aid made available by the County Council.

The building is an important survivor in the development of prefabricated cast-iron buildings. Whilst cast-iron had been in use since 1779 for bridge building, its use in buildings was limited at this period, especially in the South, the only surviving examples being in the Royal Dockyards at Portsmouth, Chatham and Sheerness, and some railway stations.

The North West Civic Trust is pleased to announce the establishment of a **Regional Information Service** which will promote the re-use of vacant buildings which are of historic or architectural interest. The Service is being supported by the Department of the Environment for an initial period of twelve months, and has been prompted by increasing concern about the vacancy and under-use of historic buildings throughout our towns and cities. Having identified such buildings the Regional Information Service will endeavour to assess the possible uses to which such buildings could be put and then disseminate information to a wide range of agencies in the property field, with a view to making prospective purchasers more aware of these buildings and so increase the possibilities for their future use.

It is anticipated that the Regional Information Service will concentrate on the following:

- 1 Gathering information about vacant buildings throughout the North West, concentrating initially on buildings which are of architectural and historic interest but also considering other buildings in sensitive areas, eg Conservation Areas.
- 2 Assessing possible future uses for these buildings.
- 3 Drawing up design guidelines where restoration or rehabilitation is required.
- 4 Providing a quarterly digest of information about vacant buildings which can be distributed to a variety of property agencies and prospective purchasers.

We also hope that the Service will provide a 'matching-up' facility whereby agencies with specific needs in the property market could be directed towards vacant buildings.

We would be very interested to hear both from those who know of vacant historic buildings which might benefit from being included within the Regional Information Service as well as from anybody who might be interested in making use of such buildings.

For further information please contact: Mrs Pauline Roscoe, Deputy Director (Administration), North West Civic Trust, The Environmental Institute, Greaves School, Bolton Road, Swinton, Manchester M27 2UX, telephone 061-794-9314.

The Herefordshire and Gloucestershire Canal Society. Begun in 1792, completed in 1845, closed in 1881 – small wonder that the Herefordshire and Gloucestershire Canal has until recently been all but forgotten. 'Throughout the length and breadth of England, no major navigation is so lost in obscurity as the Hereford and Gloucester canal' wrote one historian.

Yet it was for many years a major route for goods in and out of Hereford at a time when the

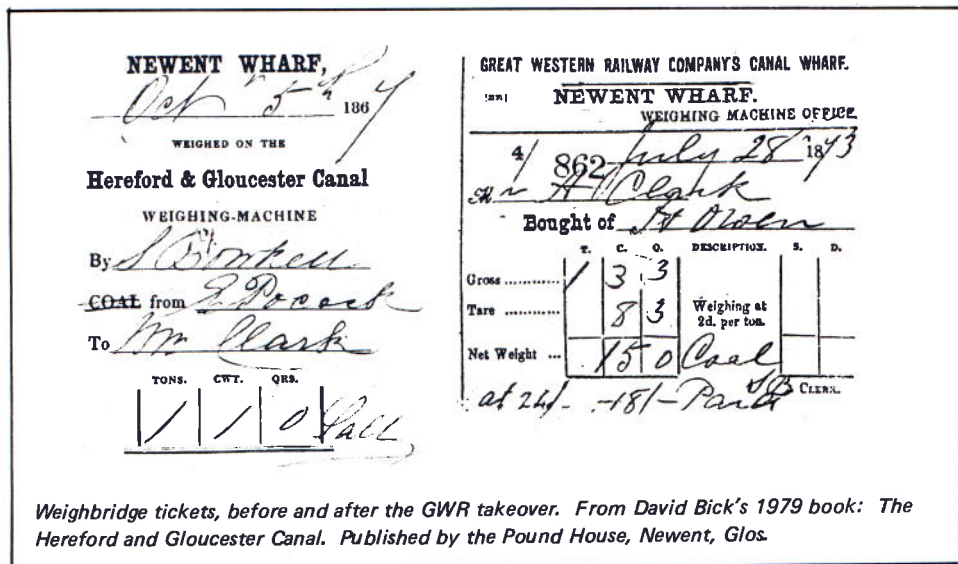

Weighbridge tickets, before and after the GWR takeover. From David Bick's 1979 book: *The Hereford and Gloucester Canal*. Published by the Pound House, Newent, Glos.

roads were poor, the railway had not yet arrived and the currents of the meandering Wye were uncertain and sometimes treacherous. The brightly coloured narrowboats must have been a familiar sight in the Herefordshire and Gloucestershire countryside, and many a boatman must have passed Withington Lock with the satisfaction of knowing that he would soon be at his journey's end.

History. The original Act of Parliament authorising construction of the Herefordshire and Gloucestershire Canal was passed in April 1791. The Canal Company was permitted to raise up to £105,000 and by 1792 had already done so, the shareholders having been attracted by exaggerated promises of profits to be made from carrying coal from the Newent coalfield. Construction began at Gloucester with Josiah Clowes as Engineer and by 1798 the canal had reached Ledbury. But all the money had been spent and the major source of water, the River Frome, had not been reached, so the 16-mile canal with 13 deep locks was always short of water. The promised trade did not materialise and the canal languished.

In 1827 Stephen Ballard was appointed Clerk. Young and enthusiastic, he set about completing the canal. A new committee was appointed and money raised in spite of the spectre of railway competition looming on the horizon. Construction started again and eventually on 22 May 1845 the canal basin at Hereford was filled and the last main line canal in England (outside Birmingham and excepting the much later Manchester Ship Canal) had been completed.

But now Railway Mania was at its height and negotiations to sell out to a railway company had already started. Fortunately for the canal, the railway was late in reaching Hereford and trade on the canal steadily increased, reaching 74,000 tons in 1858. In 1862 the canal was leased to the Great Western Railway for £5,000 a year, and in 1881 the Gloucester-Ledbury section was closed and railway tracks laid on the bed of the canal, deviating from the line of the canal only for the sharpest bends and the Oxenhall tunnel.

Cut off from the rest of the waterway system, the Hereford-Ledbury section fell into disuse and parts were sold off by the GWR — although the £5,000 per annum continued to be paid to shareholders of the canal until Nationalisation in 1947.

What Remains Today? The Herefordshire and Gloucestershire Canal was 34 miles long with 22 locks taking boats up to 7'6" wide and 70' long. Many features were obliterated by the railway between Gloucester and Ledbury but there is despite this a wealth of surviving remnants, notably around Newent and Oxenhall and in the section between Hereford and Ledbury. Bridges, tunnels, canalside buildings and silent lengths of water which no boat has stirred for a hundred years — these can all be seen and enjoyed by those who seek to find them. At Monkhide there is perhaps the 'skewest' canal bridge in the country the road crossing the canal at an angle of less than 30°.

The Herefordshire and Gloucestershire Canal Society was formed in 1983 to encourage greater public awareness of the Herefordshire and Gloucestershire Canal by disseminating knowledge of its past, appreciation of its present remains and examining its future amenity potential. The Society will explore the feasibility of clearing towpaths and lengths of canal where appropriate. It will co-operate with local land-owners and occupiers to ensure that full regard of their interests is observed in all aspects of its proposals.

Contact: James Dunn, Membership Secretary, Old Deanery House, Cathedral Close, Hereford.



Profile. Three more affiliated societies with very different interests.

Manchester Region IA Society was founded by people who wanted to preserve and study the industrial archaeology of the region. Founder members helped to establish the NW Museum of Science and Industry and the Society has been actively involved in the conservation of Liverpool Road Station and the creation of the new Science Museum.

Monthly lecture meetings are held on Fridays and during the summer the Society organises visits covering half-days, whole days and week-ends. Attention is paid to the recording of

industrial buildings in danger of demolition, and records are deposited in the NW Museum if concerned with Greater Manchester; in Merseyside County Museum if Cheshire material and with the Centre for NW Regional Studies at Lancaster University if Lancashire material. (One of the problems caused by Local Government re-organisation!) The Society plays a prominent part in the organisation of the NW Societies IA Conference.

Members are kept in touch by means of a quarterly newsletter. Further information can be obtained from the Hon Sec, Mrs A M George, 30 Kingsway, Worsley, Manchester M28 4FD.

Exeter Industrial Archaeology Group. The Group was formed in 1969 to cater for all those interested in IA at whatever level. During Autumn/Winter a Lecture Series is held in conjunction with the University Extra-Mural Department, together with Members' Evenings. During the Summer outings are organised to locations of IA interest. In the past some fieldwork has been done, with the recording of interesting sites under threat from development plans, but this activity has lapsed at present. The Group organises an annual IA Day at Dartington Hall and is active in the Western Societies Conferences. A successful series of booklets on local IA subjects is published and these are available from the Group and through booksellers. The Group participates in various community activities, such as the Exeter Festival, and is able to obtain useful press publicity for the IA cause from time to time. Membership is steady at 50 — 60. Secretary — Roger Eckersley, 3 Matford Avenue, Exeter EX2 4PP. Phone 73513, or contact may be made through the Economic History Department of the University of Exeter.

The Westonzoyland Engine Trust is a small (but enthusiastic!) group of volunteers who aim to restore the first steam pumping station on the Somerset Levels, and to establish a museum of steam and land drainage. The building dates from 1830, and houses an Easton and Amos drainage machine of 1861. The machine consists of a vertical two cylinder steam engine, with an overhead crankshaft geared to an Appold type centrifugal pump in the well beneath. Other items of interest include a horizontal steam engine of 1890, built by local firm W & F Wills of Bridgwater, (sadly closed in May 1983), the boiler from the telescopic bridge over the River Parrett at Bridgwater, an example of contractors narrow gauge railway, a smiths forge and vintage workshop machines. The Trust is at present appealing for funds for the erection of a workshop and Information Centre, which it is hoped will be erected later in 1983. The Group was first formed in 1977, since when it has been registered as a charity, and has leased the site from Wessex Water Authority. The station is open to the public on the first Sunday afternoon in every month, and party visits can be arranged at other times. It is 1½ miles from the village of Westonzoyland, on the Burrow-bridge road, NGR ST 340328.

For further information please contact: Mrs M Miles, Hon Secretary, WET, Rose Cottage, Lower Durston, Taunton, Som TA3 5AH. Tel: West Monkton (0823) 412713.

Reports on Regional Conferences

12th NW Region IA Conference was held on April 16 1983, hosted by the Saddleworth

Historical Society. The speakers were Bernard Barnes on **The Early Woollen Industry in Saddleworth** and David Chadderton on **The Standedge Watershed, The Road Crossings and Canal and Railway Tunnels**. A selection of guided walks was offered which delegates found it hard to choose between; there is clearly much of IA interest in the Saddleworth area.

1st SE Region IA Conference was held on April 16 1983 at the University of Surrey. The theme for this first SERIAC was **The Uses of Water**. The main speaker and subjects were:

London's Main Drainage	Dr Denis Smith GLIAS
The Gunpowder Industry	Dr G P Moss, Surrey Ind Hist Group
The Dolphin Barge Museum, Sittingbourne	Tony Ellis
Romano-British Watermills	R J Spain, Kent Arch Soc
Coultershaw Pump, the water supply to Petworth	Alan Allnutt, Sussex IA Soc
Paper Mills of Surrey	Professor Alan Crocker Surrey Ind Hist Group
Water power on the farm	Mrs Pamela Moore, Southampton University IA Group

This was a highly successful first meeting and a second one has been planned on The Development of Transport on Saturday April 7th 1984 at the University of Sussex.

Wessex Industrial Archaeology. Southampton Industrial Archaeology Group have headed a scheme to produce a Newsletter for those interested in the Industrial archaeology of Wessex. Several groups are active in this area including societies at Poole, South Wiltshire, Purbeck, the Portsmouth Dockyard Historical Society, King Alfred's College Group, the Hampshire Mills Group and a Trust working at Bursledon Windmill and Castleton Waterwheel. This exciting project to keep members in contact over a wide area is being co-ordinated by the Secretary of the Southampton Industrial Archaeology Group, Mrs Pamela Moore, 52 Park Lane, Fareham, Hants PO16 7LB, and those interested in subscribing to the Newsletter should contact her direct.

Gloucestershire Society for Industrial Archaeology. The 1982 Journal for the Gloucestershire Society has just been published and contains excellent articles of wider interest than Gloucestershire. There is a leading article on the origins of the Cinderford Coke Iron Furnace and cloth mills along the Painswick Stream. Two articles on tramroads concern the Bullo Pill and the Forest of Dean tramroads. An article on the Lightmoor Colliery winding engine contains some excellent illustrations and the future of the Gloucester Docks is also discussed. Further details of the Society can be obtained from the Secretary, Dr Ray Wilson, Oak House, Hamshill, Coaley, Dursley, Gloucestershire.

North Western Society for IA and History. Journal 3 of the above Society has just been published and contains excellent articles on steam generation at Edge Hill Liverpool and William Gossage and the Widnes soap industry.

There is also a long article by Peter Snow on the Willis branch railway. Brief articles have been contributed on the Merseyside County Archive Service, John Lacy Leatherworkers, Tramroads and chemical kilns at Spike Island, Widnes. Further details of this Society based at the Merseyside County Museums can be obtained from the Secretary, R J Webb, Broadview, 18 Boundary Lane, Heswall, Merseyside L60 5RR.

Industrial Archaeology Review. David and Marilyn Palmer will be taking over the Editorship of the **Review** from Stafford Linsley when Volume 6 has been completed. The **Review** will then cease to be published by Oxford University Press and will become the responsibility of the Association, being received by every member as part of their annual subscription.

The new journal, which will have the same title, and be of the format as the OUP Journal should be published once or twice a year and it is hoped that the first volume will be available for the 1984 Annual Conference.

The new Editors face the difficult task of maintaining the quality of both content and production established by OUP and previous editors, yet making it essentially the journal of the Association for Industrial Archaeology. Questionnaires returned suggest that you are interested in the field aspects of IA, whether of single sites or whole industries; in firms and businesses; in the practical techniques of recording, surveying and excavation, and in the social aspects of industrial history. It is also clear that some articles at present published in local society journals may well merit a wider audience.

It is hoped therefore, to produce a journal which is illustrated with maps, plans, diagrams and photographs, and which contains a balanced selection of articles in each issue. It is also felt there is room in the **Review** for rather shorter articles than in the past, as well as the more fully presented reports, but everything depends on material from you!

Many of you may not have written articles for journals before. A series of guidelines for prospective authors is being prepared and will be sent on request. Please write before you produce your material in its final form, as this could save time later on. If, however, you already have an article you are longing to see in print, do send it and you will be advised on what needs to be done to fit it into the **Review**. The Editors reserve the right both to refuse and to edit articles so that we can maintain both the balance and standard of the **Review**.

Please write to Dr Marilyn Palmer, The History Department, Loughborough University, Loughborough, Leicestershire LE11 3TU and as soon as possible.

As the Association (and the AIA Bulletin) enters its eleventh year it would seem appropriate to mention Council's thoughts concerning the future of the Bulletin now that it is to be joined by a wholly AIA produced Journal. The editors of the new Journal, Marilyn and David Palmer, are aiming to produce the first of the new series in the Summer of 1984 and by then a firm, but flexible, policy will have been established for the integration of the two publications.

No great changes are planned but there are two outstanding points which will have to be taken into account:

1 For the first time both the Bulletin and the

Journal will be entirely controlled by the Association and

2 Both publications will be received by all members and Affiliated Societies.

The second factor automatically means that the publication dates, methods of distribution and pattern of contents will need to be carefully monitored in order that Association members receive the best possible information service in the most economic manner.

During recent Council meetings discussion centred around these points and decisions made in connection with the Bulletin which will facilitate the transition period.

At the March 1983 meeting John Robinson tendered his resignation as Bulletin Editor and was succeeded by Roy Day, who up until that juncture had been acting as Production Editor. At the same meeting an 'Editorial team' was instigated in order that the membership at large should know where to aim information for eventual publication.

Naturally this list can not be definitive but it should help would-be contributors.

Association business, legal queries, insurance etc **Paul Stephens**.

Affiliated Society news etc **Janet Spavold** Conference details, education matters etc **David Alderton**.

Preservation problems, threatened sites etc **John Crompton**.

Details of research and excavations, museum news, members' correspondence, book notices and lists etc **Stuart Smith**.

Abstracting service and questions concerning bibliography etc **John Powell**.

Details of events, conferences and courses **Roy Day**.

Addresses of these Council Members are given on the AIA Council insert but if in any doubt send any information which cannot be categorised to the AIA Assistant Secretary (Stuart Smith) at Ironbridge.

Publication dates for Bulletin issues will be:
Number 1: Mid-November with a 'copy date' of September 15th.

Number 2: Mid-February (December 15th).

Number 3: Mid-May (March 15th).

Number 4: End of August (June 15th).

AIA Bulletin

ISSN 0309-0051.

Is edited by Roy Day from 3 Oakfield Road, Keynsham, Bristol BS18 1JQ and is published by the Association for Industrial Archaeology. The AIA was established in September 1973 to promote the study of Industrial Archaeology and encourage improved standards of recording, research, conservation and publication. It aims to assist and support regional and specialist survey and research groups and bodies involved in the preservation of industrial monuments, to represent the interest of Industrial Archaeology at national level, to hold conferences and seminars and to publish the results of research. Further details may be obtained from the Membership Secretary, Association for Industrial Archaeology, The Wharfage, Ironbridge, Telford, Shropshire, TF8 7AW, England. Telephone 095-245-3522.